

Manufacturers Specifications

Water Pressures

- Tested to maximum 3500 kPa (Valve closed-Spout Open)
- Tested to minimum 40 kPa
- Recommended max. 500 kPa
- Recommended min. 40 kPa

Pressure limiting valves are required where working, static or kinetic pressure exceeds 500 kPa

Your mixer has been built from the best available materials and has been manufactured to the highest Australian and overseas standards.

The mixer is guaranteed by the manufacturer for 1 year parts & labour and 15 years parts only. Failure to comply with these installation instructions will void this warranty.

ALS-41303

Sink Mixer

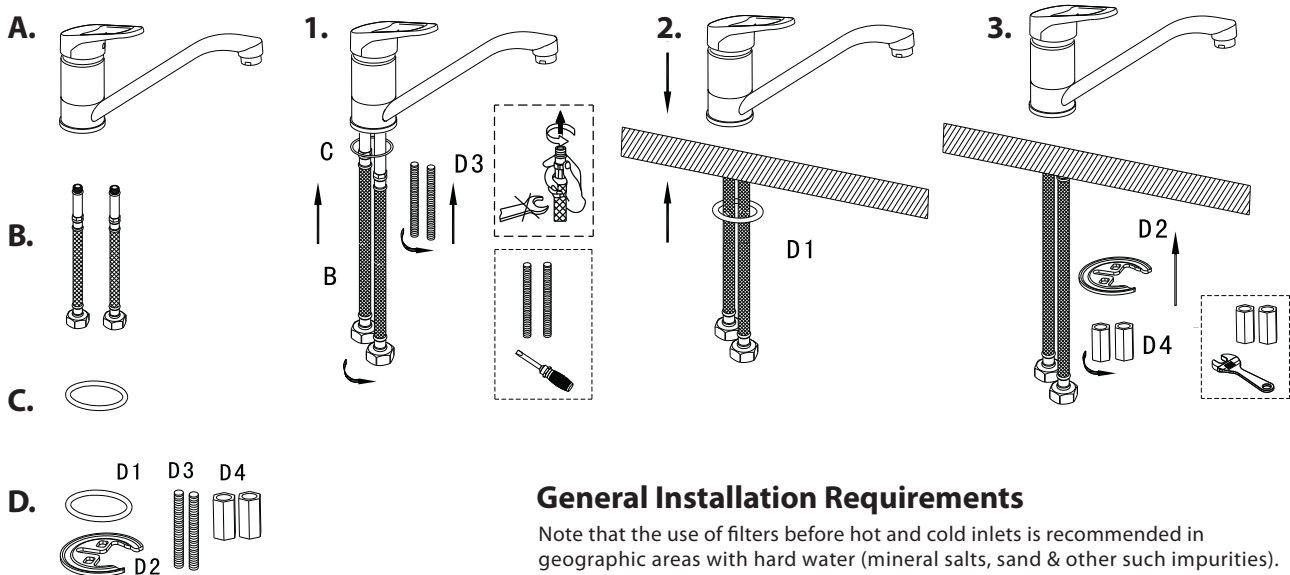

General Installation Requirements

Note that the use of filters before hot and cold inlets is recommended in geographic areas with hard water (mineral salts, sand & other such impurities). All mixers are designed for mains pressure, equal for both hot and cold water. ALL PIPES SHOULD BE FLUSHED OUT BEFORE INSTALLING THE MIXER

Maintenance

Should service be required on your mixer, particularly for the ceramic disk cartridge, please contact your distributor.

Cleaning Suggestions

Use only clean soap and water with a soft sponge or cloth. DO NOT USE ANY DETERGENTS OR CREAM CLEANERS. The aerator screwed into the end of the water outlets of the basin and sink mixers should be regularly checked and cleaned by removing and brushing.

NOTE: For Shower and Diverter Style Mixers Only

1. Once the mixer is plumbed in and the wall sheeting (tiles) installed, the gap around the mixer body must be properly filled with silicon to prevent wall surface penetrating behind the face plate into the wall cavity.
2. Keep plastic protective cover over the mixer body and diverter arm until all wall work (tiling, grouting) is complete.
3. Diverter mixer includes a chrome adaptor for water supply to bath (1/2" female BSP). Installing plumber must correctly seal the adaptor connections using tape and paste

IMPORTANT

Pressure & Temperature Required

Hot and cold water inlet pressures should be equal. Inlet pressure range : 150-1000 kPa.

New Regulation: 500 kPa maximum operating pressure at any outlet within a building. (Ref.AS/NZS 3500. 1-2003, Clause 3.3.4

Maximum hot water temperature : 80°C.

Deck Requirements

Deck thickness : 30mm maximum
Tap body hole (in deck) : Ø30

PACO JAANSON FINE BATHROOMS

Telephone : 1800 006 260

www.pacojaanson.com.au